

## Guidelines for the Use of Glass in Protective Barriers

7.2 November 2014

### Contents

Introduction

1. Scope

2. Definitions and descriptions

3. Design considerations

4. Design criteria

5. Barrier types

6. Glass types

7. Installation

Bibliography

Annex A Conformity with U.K. Building Regulations

### Introduction

Glazing in protective barriers can be regarded as a 'safety risk' if an individual can accidentally come into contact with it.

There are two specific risks that need consideration and these are:

- Cutting and piercing injuries resulting from accidental impact;
- Falling through the glazing if the impact causes breakage

NOTE: Injuries resulting from walking into unseen glazing is excluded from this Data Sheet. This risk can be alleviated by the use of appropriate manifestation. Advice on manifestation can be found in BS 6262-4:2005, GGF Publication 'The Right Glazing in the Right Place' and the applicable Building Regulations.

### 1. Scope

This Data Sheet covers the use of glass in protective barriers (generally referred to as balustrades) that are designed to offer protection to people where a difference in height constitutes a falling risk.

It covers:

- a. Full height protective barriers
- b. Balustrades with glass infill panels
  - i. Fully framed
  - ii. Edge supported
  - iii. Point/clip supported
- c. Free standing glass protective barriers

As well as giving the basis of design there is an Annex that covers the situation with respect to conformity with Building Regulations in the United Kingdom.

It does not cover curved glass when used in the above applications.

### 2. Definitions and Descriptions

NOTE: Definitions 2.1.1, 2.1.2, 2.1.3 and Figure 1 are reproduced from the appropriate Building Regulations eg Approved Document K.

#### 2.1 Definitions

##### 2.1.1 Barrier

Any element of building or structure intended to prevent persons from falling and to retain, stop or guide persons

##### 2.1.2 Datum

Finished level on which people may stand, e.g. floor; roof; balcony; pitch line of stairs external ground, etc. (see Figure 1)

##### 2.1.3 Design level

Level at which the horizontal force on the barrier is assumed to act for the purpose of design (see Figure 1)

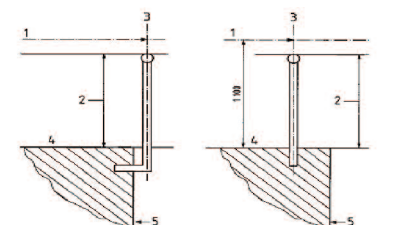

#### Key

- |                   |                      |
|-------------------|----------------------|
| 1 Design level    | 5 Edge of floor      |
| 2 Barrier height  | 6 Datum = pitch line |
| 3 Horizontal load | 7 stairs             |
| 4 Datum = FFL     |                      |

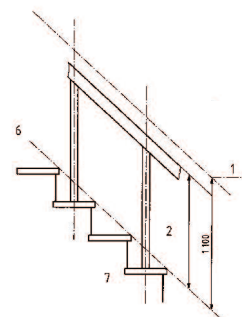

**Figure 1**  
Datum, barrier height  
and design height



Glass and Glazing Federation

**Glass and Glazing Federation**  
54 Ayres Street, London. SE1 1EU  
Tel: 020 7939 9100 Fax: 0870 042 4266  
[www.ggf.org.uk](http://www.ggf.org.uk)

While every attempt is made to present up to date information, this data sheet, produced by the Glass and Glazing Federation, is issued for guidance but without responsibility for any advice given therein or omission therefrom or for the consequences of acting in reliance thereon and all liability on the part of the Glass and Glazing Federation however arising in connection therewith is expressly disclaimed.

### 2.1.4 Line load

Load, i.e. horizontal force, which is applied at the design height

### 2.1.5 Uniformly distributed load

Load, e.g. wind loading, applied over the entire surface area of the pane

### 2.1.6 Concentrated load

Load applied over a small area

### 2.1.7 Impact load

The load applied when a person falls against the barrier.

### 2.1.8 Containment

Ability of glazing when subjected to impact loading to resist penetration and hence prevent people from falling through it.

NOTE 1: Thermally toughened safety glass will provide containment when under the applicable impact test it does not break.

NOTE 2: Laminated safety glass will provide containment when under the applicable impact test it either does not break or breaks safely.

NOTE 3: Applicable impact test method, i.e. EN 12600.

### 2.1.9 Baluster

Post supporting the handrail in a balustrade.

### 2.1.10 Handrail

Rail acting as a guard or support to be held by hand in a balustrade.

NOTE: It enables the line load to be transmitted to the structure without stressing the glass. With the exception of free standing protective barriers i.e. 2.2.3 the handrail shall be connected to the balusters.

## 2.2 Descriptions

### 2.2.1 Full height protective barrier

These can take many forms and are not necessarily composed of full floor to ceiling glass/glazing. If any part of a glazed structure, whether it forms the whole or part of a wall element, extends below the minimum barrier height given in 4.5 it is classed as a full height barrier. See Figure 2.

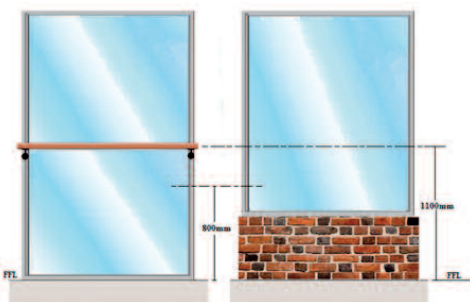

Figure 2 Examples of full height protective barriers

NOTE: Compliance can be achieved by: installing an appropriate handrail; or ensuring that the glass specification will withstand the appropriate loading.

### 2.2.2 Barrier with glass infill panel

This type of protective barrier comprises the main frame, i.e. handrail and balusters, which carry the appropriate loads. The glass is used to form the infill panel and provides no support to the main frame. Handrail loads are not transferred to the glass infill.

There are four main types of infill panels (see figure 3):

- Fully framed;
- Two edge framed
- Clip fixed
- Bolt fixed

The two edge frames, clips and bolts can relate to infill panes in either landscape or portrait format.

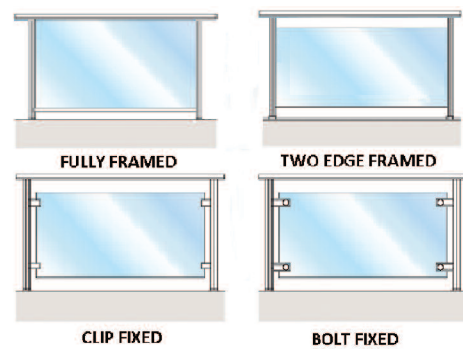

Figure 3 Examples of infill panels

NOTE: The application of a structural sealant between adjacent panes of glass does not change the support condition.

### 2.2.3 Free-standing glass protective barrier

This type of protective barrier consists of glass panes affixed, e.g. clamped or bonded, to the structure along the bottom edge (see figure 4). A handrail is generally attached to the top edge of the glass and there are no balusters.

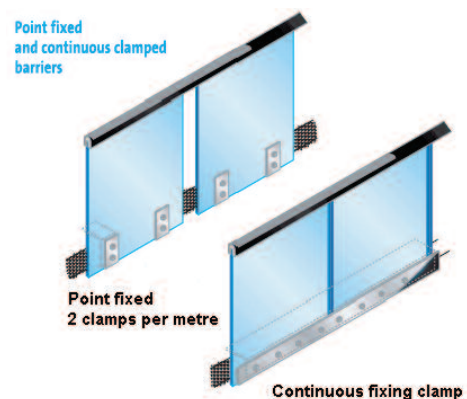

Figure 4 Examples of free-standing protective barriers

## 3. Design Considerations

### 3.1 Assessment

When assessing the need for a barrier and the type of barrier to

## Guidelines for the Use of Glass in Protective Barriers

be provided, consideration should be given to the likely hazards, building use and the risks to building users.

Where, in a building, more than one use of the building is anticipated, either the barrier design should be chosen to suit the worst case, or more than one type of barrier should be provided, as appropriate, to the location.

### 3.2 Difference in levels

The protective barrier shall provide guarding when the following apply:

- In dwellings where the difference in adjacent level is  $> 600\text{mm}$ ;
- In building other than dwellings where the difference is:
  - On stairs greater than two risers;
  - Other location  $> 380\text{mm}$

### 3.3 Other considerations

The barrier selected shall be designed so as to minimise the risk of persons falling, rolling, sliding or slipping through gaps in the barrier and/or the infill.

Where barriers are used when children under five are present the gap in the barrier shall not exceed  $100\text{mm}$ . This dimension is given with the applicable Building Regulation.

NOTE 1: The  $100\text{mm}$  is to prevent the child being held fast by the guarding (see applicable Building Regulation in Bibliography [B1])

NOTE 2: Any guarding protecting glazing has to prevent a sphere of  $75\text{mm}$  diameter touching the glazing (see applicable building regulation in Bibliography [B1])

NOTE 3: The break safe criteria for laminated safety glass and wired safety glass are that no opening through which a  $76\text{mm}$  diameter sphere can pass. (see EN 12600)

N.B: Care should be taken to consider the possible deflection under loading.

## 4. Design Criteria

### 4.1 Introduction

The presence of protective barriers may be one of guidance for persons moving about a building. However, the majority of protective barriers are positioned to prevent persons from falling from the edges of floors, stairs, elevated walkways and roofs.

The main requirement of a protective barrier is, therefore, to provide containment. It performs this function by being able to resist the likely applied forces without excessive deflection and without being penetrated.

The forces to be resisted are generally described as follows:

- **Line load** is related to the possibility of persons leaning against the barrier; applying a force normal to a conventional barrier at the top edge. It is generally given in the form of  $\text{kN/m}$  run, applied at a height above finished floor level, i.e. datum, roughly equivalent to the waist height of an adult
- **Uniformly distributed load (UDL)** is related to the pressure exerted on the infill area (that part of the barrier below the position of application of the line load). It is generally given in the form of  $\text{kN/m}^2$ , applied over the entire infill area.

- **Concentrated load** takes into account any non-uniformity of the load applied to the infill and may also represent a static equivalent to a localised human impact (from hand, knee, elbow, etc.). It is generally given in the form of  $\text{kN}$ , applied at the most vulnerable position on the infill area.

NOTE 1: Line and concentrated loads are given in Eurocode EN 1991-1-1 and are the subject of a National Annex.

NOTE 2: Uniformly distributed loads are given in Eurocode EN 1991-1-4 and are the subject of a National Annex.

NOTE 3: Minimum horizontal imposed loads for parapets, barriers and balustrades are provided in Table 2 of BS 6180: 2011

N.B: Barriers shall be designed to resist the most unfavourable likely imposed loads, i.e. line and concentrated; and wind loads without unacceptable deflections or distortions.

### 4.2 Load values

The value of the design loads shall relate to the building usage. Buildings with higher usage levels will generally be designed to higher load levels.

The design loads and building usage categories can be found in applicable national Building Regulations.

### 4.3 Impact loading

In addition to the loading requirements given in 4.1, which are applicable to any design of barrier, where glass is used, the performance under impact must be considered.

Impact performance of glazing is determined under material testing. In Europe the appropriate standard is EN 12600. The classification of flat glass under this test method is presented as follows:

#### $\alpha(\beta)\Phi$

Where:

- $\alpha$  is the highest drop height class at which the product either did not break or broke in accordance with a) or b) of EN 12600: 2002, Clause 4;
- $\beta$  is the mode of breakage (see Annex A of EN 12600);
- $\Phi$  is the highest drop height class at which the product either did not break or broke in accordance with a) of EN 12600: 2002, Clause 4.

### 4.4 Impact classes

The energy level of an impact will vary according to the position of the barrier relative to the unhindered distance a body can travel in a direction perpendicular to the surface of the protective barrier (free path - see figure 5).

The minimum impact classes that shall be used are dependent upon the glass type and the free path.

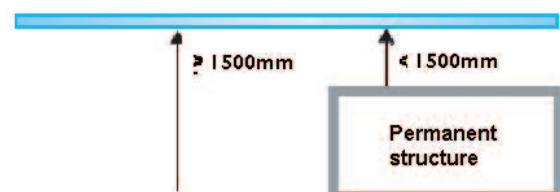

Figure 5 Free path

## Guidelines for the Use of Glass in Protective Barriers

For glass to be used within a free-standing glass protective barrier, or a barrier with a glass infill panel it MUST give containment. Therefore the impact classes that shall be used are as follows:

- Free path up to 1500mm
  - Thermally toughened safety glass minimum 3(C)3, i.e. 6mm
  - Laminated safety glass minimum 3(B)3, i.e. 6.4mm
- Free path over 1500mm
  - Thermally toughened safety glass 1(C)1, i.e. 10mm
  - Laminated safety glass 1(B)1, i.e. 6.8mm

### 4.5 Barrier heights

The heights of barriers above datum are shown in Figure 1. These are given below:

- Single family dwelling
  - Barriers in front of a window 800mm
  - Stairs, landings, ramps, edges of internal floors 900mm
  - External balconies, edges of roofs 1100mm

All other uses

- Barriers in front of a window 800mm
- Stairs 900mm
- Other positions 1100mm
- Balconies and stands, etc. having fixed seating within 530mm of the barrier (see figure 6) 800mm

NOTE: BS 6180:2011 gives the following barrier height/building usage:

- Balconies and stands, etc. having fixed seating within 530mm of the barrier provided the sum of the barrier width and the barrier height is greater than 975mm

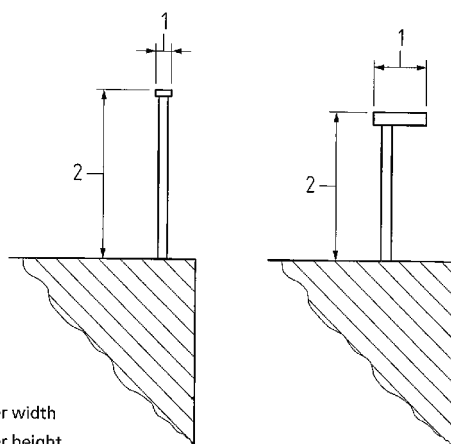

**Figure 6 Height and width of barriers in front of fixed seating**

## 5. Barrier Types

### 5.1 General

The details below relate to the most commonly used types of barriers.

There are other commercial systems available that can equally provide a suitable barrier.

### 5.2 Full height glazed protective barrier

#### 5.2.1 General

This is where glazing as part of an internal or external wall protects a difference in level. The glass may be glazed on 4-edges, 2-edges or be bolt fixed. It may be single glazing or insulating glass units.

#### 5.2.2 Loading

Glass partially or totally below the barrier height shall be designed to satisfy the appropriate design criteria. Any part of a glass pane below the barrier height shall sustain the infill loads. Where the barrier height is coincident with the glass, the glass shall also sustain the line load applied at the appropriate height.

N.B. The glass shall have an impact performance classification in accordance with the safety glazing recommendations given in BS 6262-4 i.e. have an appropriate EN12600 classification. Using a thin glass, e.g. 4mm toughened Class 1(C)1, does not necessarily mean that the glass is capable of carrying all applicable loads.

NOTE: The choice of glazing type and thickness requires consideration of other factors such as wind loading, etc.

#### 5.2.3 Deflection

The deflection of the glass, when it is subjected to the design loads, shall be limited to  $L/65$  or 25mm, taking L as the longest dimension of the glass.

### 5.3 Barrier with glass infill panel

#### 5.3.1 General

In this type of protective barrier, the main frame, comprising of the handrail and baluster, is designed to withstand the line loads applied to the hand rail, and the glass is used to form the infill panels. The glass in no way provides any support to the main frame, and the handrail loads are not transferred to the glass.

#### 5.3.2 Loading

The glass infill panel shall carry the applicable loads, i.e. UDL and concentrated.

With external applications the wind loading shall also be considered.

#### 5.3.3 Support conditions

### 5.3.3.1 Fully framed (see figure 7)

The frame section shall give a minimum of 15mm edge cover to the glass



Figure 7 Fully framed infill panel

### 5.3.3.2 Two-edge framed (see figure 8)

The frame section shall give a minimum of 15mm edge cover to the glass on those edges that are framed.



Figure 8 Two-edge framed infill panel

### 5.3.3.3 Clip Fixed (see figure 9)

The clips should be positioned around the periphery of the infill panel, at a maximum spacing of 600 mm. Each clip should be not less than 50 mm in length and should give a minimum depth of cover to the glass of 25 mm.

Depending upon the actual number, size and spacing of the clips, the glass may be considered fully framed or two-edge framed.



Figure 9 Clip fixed infill panel

NOTE: This example shows a two edged framed panel. The addition of clips along top and bottom edge would be considered as fully framed.

### 5.3.3.4 Bolt fixed (see figure 10)

The design of the bolt fixings is detailed in clause 7.2 of BS 6262-6: Glazing for building – Part 6: Code of practice for special applications

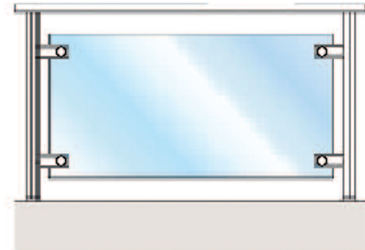

Figure 10 Bolt fixed infill panel

### 5.3.4 Deflection

The deflection of the glass, when it is subjected to the design loads, shall be limited to  $L/65$  or 25mm, taking L as the maximum span between the supporting points, unless the pane is fully framed, in which case L is the longer dimension of the glass.

## 5.4 Free-standing glass protective barrier

### 5.4.1 General

In this type of protective barrier; the glass is designed to withstand all the design loads. Each glass pane is either clamped or adhesively fixed to the structure along its bottom edge, the handrail is attached to the top edge of the glass, and there are no balusters.

The design of the clamping is detailed in clause 7.2.3 of BS 6262-6: Glazing for building – Part 6: Code of practice for special applications

### 5.4.2 Loading

All barriers loads, i.e. UDL, concentrated and line loads, shall be carried by the glass pane. In external applications wind loading shall also be considered.

### 5.4.3 Deflection

The deflection of the glass, when it is subjected to the design loads shall be limited to  $L/65$  or 25mm, taking L as the distance between the clamping and the top edge of the plate.

## 6. Glass Types

### 6.1 General

The type and thickness of glass shall be chosen to suit the design of the protective barrier and the applicable loads.

### 6.2 Glass types

The following glass types are suitable for installation into protective barriers; subject to the limitations given in 6.3

- Thermally toughened soda lime silicate safety glass in accordance with EN 12150-2;
- Heat soaked thermally toughened soda lime silicate safety glass in accordance with EN 14179-2;

## Guidelines for the Use of Glass in Protective Barriers

---

- Laminated safety glass in accordance with EN 14449;
- Laminated thermally toughened soda lime silicate safety glass in accordance with EN 14449;
- Laminated heat soaked thermally toughened soda lime silicate safety glass in accordance with EN 14449.
- Laminated heat strengthened soda lime silicate safety glass in accordance with EN 14449
- Safety rated wired glass in accordance with EN 572-9

NOTE: Thermally toughened safety glass and heat soaked thermally toughened safety glass are available for other glass compositions, e.g. borosilicate, alkaline earth silicate.

### 6.3 Limitations

Some types of laminated safety glass can only be used fully framed, i.e. in full height glazing or in barriers with fully framed infill panels.

NOTE: Laminated thermally treated glasses may be used without being fully framed.

Safety rated wired glass can only be considered for fully framed full height barrier situations.

All other glass types detailed above are suitable for installation in conventional systems.

### 7. Installation

Care should be taken to ensure there is no glass to metal contact. The major points are as follows:

- Gaskets shall be used when the glass is glazed into channels
- When glazed using clips, appropriate material shall be used to prevent the clips contacting the glass surface
- Point fixed panes require the use of a bush around the bolt and incompressible gasket between the spreader plates and the glass.

NOTE: Information on design of point support fixings can be found in BS 6262-6'

### Bibliography

#### B1 United Kingdom Building Regulations:

England –

Approved Document K: 2013 - Protection from falling, collision and impact

K1 Stairs, ladders and ramps

K2 Protection from falling

K4 Protection against impact with glazing

K5 Additional provisions for glazing in buildings other than dwellings

Wales –

Approved Document K – Protection from falling, collision and impact – Parts K1, and K2

NOTE: Formerly England & Wales AD K

Approved Document M – Access to and use of buildings

NOTE: Formerly England & Wales Approved Document M– 2004 incorporating 2010 amendments

Approved Document N – Glazing - Safety in relation to impact, opening and cleaning – Part N1 and N2

NOTE Formerly England & Wales Approved Document N – 1998 incorporating 2000 and 2010 amendments

Scotland –

Building (Scotland) Regulations Technical Handbook – Domestic and Non-Domestic – Section 4 - Safety

Section 4.4 – Pedestrian protective barriers

Section 4.8 – Danger from accidents

Northern Ireland –

The Building Regulations (Northern Ireland) Statutory Rules – Technical Booklet H – Stairs, ramps, guarding and protection from impact

The Building Regulations (Northern Ireland) Statutory Rules – Technical Booklet V - Glazing

#### B2 British Standards

BS 6180: 2011: Barriers in and about buildings – Code of practice

BS 6262-4: 2005 Glazing for buildings – Part 4: Safety related to human impact – Code of practice

BS 6262-6: 2005 Glazing for buildings – Part 6: Code of practice for special applications

#### B3 European Standards

EN 572-9: Glass in building – Basic soda lime silicate glass products – Part 9: Evaluation of conformity/Product standard

EN 1863-2: Glass in building – Heat strengthened soda lime silicate glass – Part 2: Evaluation of conformity/Product standard

EN 12150-2: Glass in building – Thermally toughened soda lime silicate safety glass – Part 2: Evaluation of conformity/Product standard

EN 12600: Glass in building – Pendulum test – Impact test method and classification for flat glass

EN 13024-2: Glass in building – Thermally toughened borosilicate safety glass – Part 2: Evaluation of conformity/product standard

EN 14179-2: Glass in building – Heat soaked thermally toughened soda lime silicate safety glass – Part 2: Evaluation of conformity/Product standard

EN 14321-2: Glass in building – Thermally toughened alkaline earth silicate safety glass – Part 2: Evaluation of conformity/product standard

EN 14449: Glass in building – Laminated glass and laminated safety glass – Evaluation of conformity/Product standard

EN 15682-2: Glass in building – Heat soaked thermally toughened alkaline earth silicate safety glass – Part 2: Evaluation of conformity/product standard

BS EN 1991-1-1: EUROCODE 1: Part 1-1, General actions – Densities, self-weight and imposed loads

BS EN 1991-1-4: EUROCODE 1: Part 1-4, General actions – Wind actions

#### B4 Other Documents

Young, Warren C. and Raymond Roark. Roark's Formula for Stress and Strain. 8th Edition, McGraw-Hill 2012

## Annex A Conformity with U.K. Building Regulations

### A.1 General

The Building Regulations [B1] in the United Kingdom incorporate requirements to provide barriers when it is necessary to protect people in and about buildings from falling.

NOTE: All tables contained within this Annex have been prepared to summarise the requirements. However, they are not part of the Building Regulations.

### A.2 Building occupancy classes

The Building Regulations [B1] classify building types and usage with relationship to applicable imposed loads for protective barriers. Table A1 shows occupancy types that have the same applied loads.

Class	Occupancy
1	Domestic and Residential – single family dwellings Office and Work Areas – light pedestrian traffic routes
2	Domestic and Residential – multi-occupancy, balconies and edges of roofs  Office and Work Areas – areas not susceptible to over crowding  Areas without obstacles for moving people and not susceptible to over crowding – stairs, landing, corridors, and balconies
3	Areas where people might congregate – areas having fixed seating within 530mm of the barrier  Areas with tables or fixed seating – restaurants and bars  Areas susceptible to over crowding – footways or footpaths less than 3 metres wide, adjacent to sunken areas  Retail areas – all retail areas including banks, building societies or betting shops
4	Areas susceptible to over crowding – theatres, cinemas, shopping malls, assembly areas. Footways or pavements greater than 3 metres wide adjacent to sunken areas

**Table A1 Classification of building occupancy types by barrier loadings.**

### A.3 Applicable loadings

Table A2 gives the applicable loadings dependant upon the building occupancy classification (see table A1).

Building Occupancy Class	Design Loads		
	Line load in kN/m run applied 1100mm above finished floor level	UDL in kN/m <sup>2</sup> applied to the whole of the infill panel below the line load height	Concentrated load in kN applied to any part of the infill panel below the line load height
1	0.36	0.5	0.25
2	0.74	1.0	0.5
3	1.5	1.5	1.5
4	3.0	1.5	1.5

**Table A2 Design loads for protective barriers**

## A4 Sizes of glass that comply with the design loads of protective barriers

### A4.1 General

The size of glass panels that will carry the loads given in Table A2 are dependant upon the type of barrier and support conditions.

### A4.2 Full height barriers

Table A3 gives information on single glazed full height barriers.

Building Occupancy Class	Nominal Glass thickness (mm)	Area in m <sup>2</sup> for glass type		
		Laminated Safety Glass	Thermally Toughened Safety Glass	Safety Wired Glass
1	6	3.2	3.6	2.8
	8	5.7	5.8	
	10	9.0	9.0	
	12	12.2	12.2	
	≥15	No limit	No limit	
2	6	1.0	2.4	n/a
	8	3.6	4.0	
	10	6.2	6.2	
	12	9.0	9.6	
	15	-	12.2	
	16	12.2	-	
	≥19	No limit	No limit	
3	6	n/a	n/a	n/a
	8	n/a	0.5	
	10	n/a	4.0	
	12	0.8	5.7	
	15	-	9.0	
	16	10.2	-	
	19	-	15.2	
	20	17.6	-	
	≥24	No limit	No limit	
4	any	n/a	n/a	n/a

**Table A3 Maximum allowable pane sizes for single glazed full height barriers**

N.B. This table has recently been amended to reflect the revision of Roark's Formulas for Stress and Strain.

## Guidelines for the Use of Glass in Protective Barriers

NOTE 1: Glass panes within these sizes will satisfy the design criteria irrespective of shape and for glazing methods which support the glass panel on all edges.

NOTE 2: Compliance with this table does not necessarily indicate suitability for purpose. The thickness and type of glass pane that can be used may also be affected by other criteria, e.g. wind loads, and these should also be taken into account when selecting the glass.

NOTE 3: Thermally toughened safety glass should comply with EN 12150 and have a classification according to EN 12600 of 1(C)

NOTE 4: Laminated safety glass should comply with EN 14449 and have a classification according to EN 12600 of 3(B)

NOTE 5: Laminated safety glass is assumed to be symmetrical, i.e. nominal 6mm comprises two leaves of 3mm glass.

### A4.3 Full height barriers

Table A4 gives information on full height barriers - glazed with insulating glass units.

The following notes apply

NOTE 1: The outer leaf may be one of the following:-

- Annealed float Glass
- Laminated Safety Glass
- Heat strengthened float glass

NOTE 2: The outer leaf may be one of the following:-

- Annealed float Glass
- Laminated Safety Glass
- Heat strengthened float glass
- Thermally toughened float safety glass

Building Occupancy Class	IGU configuration (mm)	Area in m <sup>2</sup> for glass type		
		Laminated Safety Glass - Inner leaf Outer leaf See Note 1	Thermally Toughened Float Safety Glass Inner leaf. Outer leaf See note 2	Laminated Inner leaf / Toughened Outer leaf
1	4+4	n/a	2.2	n/a
	6+6	4.4	4.8	4.8
	8+8	9.0	9.0	9.0
	10+10	14.4	15.2	14.8
2	4+4	n/a	0.15	n/a
	6+6	2.8	3.2	3.0
	8+8	5.2	5.5	5.5
	10+10	9.0	9.0	9.0
3	4+4	n/a	n/a	n/a
	6+6	n/a	n/a	n/a
	8+8	n/a	1.4	n/a
	10+10	0.15	5.2	0.15
4	4+4	n/a	n/a	n/a
	6+6	n/a	n/a	n/a
	8+8	n/a	n/a	n/a
	10+10	n/a	3.2	n/a

**Table A4 Maximum allowable pane sizes for insulating glass units in full height barriers**

NB This table has recently been amended to reflect the revision of Roark's Formulas for Stress and Strain

NOTE 1: Glass panes within these sizes will satisfy the design criteria irrespective of shape and for glazing methods which support the glass panel on all edges.

NOTE 2: Compliance with this table does not necessarily indicate suitability for purpose. The thickness and type of glass pane that can be used may also be affected by other criteria, e.g. wind loads, and these should also be taken into account when selecting the glass.

NOTE 3: Thermally toughened safety glass should comply with EN 12150 and have a minimum classification according to EN 12600 of 1(C)3

NOTE 4: Laminated safety glass should comply with EN 14449 and have a minimum classification according to EN 12600 of 3(B)3

NOTE 5: Laminated safety glass is assumed to be symmetrical, i.e. nominal 6mm comprises two leaves of 3mm glass.

NOTE 6: Annealed float glass should comply with EN 572-2.

NOTE 7: Some of the sizes indicated may not be practical from a manufacturing or handling perspective. Please contact the unit supplier for information on their maximum available sizes."

NOTE 8: the minimum impact classification will depend on free path. See Clause 4.4

NOTE 9: For insulating glass units the loads can be shared between the individual leaves.

N.B. In the case of insulating glass units the loads can be shared between the individual leaves. Advice should be sought from the unit manufacturer:



#### A4.4 Barriers with glass infill panels

Table A5 gives information on fully framed glass infill panels. It covers toughened safety glass and laminated safety glass.

Infill loading criteria		Nominal glass thickness mm		Maximum size mm
Concentrated Load kN	UDL kN/m <sup>2</sup>	Toughened safety glass	Laminated safety glass	
0.25	0.5	6	6.4	2.0
0.5	1.0	6	8.4	2.0
1.5	1.5	10	12.4	0.8

**Table A5 Allowable thickness for fully framed infill panels**

NOTE 1: Thermally toughened safety glass should comply with EN 12150 and have a classification according to EN 12600 of 1(C)1.

NOTE 2: Laminated safety glass should comply with EN 14449 and have a classification according to EN 12600 of 2(B)2.

NOTE 3: Glass panes within these sizes will satisfy the design criteria irrespective of shape and for glazing methods which support the glass panel on all edges.

NOTE 4: Compliance with this table does not necessarily indicate suitability for purpose. The thickness and type of glass pane that can be used may also be affected by other criteria, e.g. wind loads, and these should also be taken into account when selecting the glass.

NOTE 5: Laminated safety glass is assumed to be symmetrical, i.e. nominal 6mm comprises two leaves of 3mm glass.

**Table A6 gives information on two-edge framed infill panels with thermally toughened soda lime silicate safety glass**

Infill loading		Panel Width mm	Span Limits mm			
UDL kN/m <sup>2</sup>	Concentrated Load kN		6mm *	8mm *	10mm	12mm
0.5	0.25	300	900	1450	1900	2300
		500	1150	1750	2100	2400
		700	1350	1750	2100	2400
		900	1350	1750	2100	2400
1.0	0.5	300	600	1000	1450	1800
		500	750	1250	1750	2050
		700	900	1450	1750	2050
		900	950	1450	1750	2050
1.5	1.5	300	n/a	n/a	550	900
		500	n/a	n/a	950	1400
		700	n/a	n/a	1150	1600
		900	n/a	n/a	1300	1700

**Table A6 Maximum allowable spans for two-edge framed thermally toughened safety glass infill panels.**

Where:

Span is distance between supports which can be on either the vertical or horizontal edges of the pane;

Pane width is either horizontal or vertical dimension depending upon orientation of pane and 90° to the span.

NOTE 1: n/a = not applicable for this load category

NOTE 2: \* = Possibly not suitable for free paths greater than 1500mm, unless the glass complies with Note 3 with respect to EN 12600 classification.

NOTE 3: Thermally toughened safety glass should comply with EN 12150 and have a classification according to EN 12600 of 1(C)1.

NOTE 4: Compliance with this table does not necessarily indicate suitability for purpose. The thickness and type of glass pane that can be used may also be affected by other criteria, e.g. wind loads, and these should also be taken into account when selecting the glass.

#### A4.5 Free standing glass protective barriers

Table A7 gives information on free standing glass protective barriers see 2.2.3. The glasses used are thermally toughened soda lime silicate safety glass or laminated thermally toughened soda lime silicate safety glass. They may be heat treated.

Laminated thermally toughened soda lime silicate safety glass shall have a handrail to give protection in case of glass breakage.

Laminated thermally toughened soda lime silicate safety glass may be installed without a handrail as the design incorporates two panes of glass. If a pane is broken the unbroken pane will continue to give containment.

**Table A7 Thickness of glass required for single glazed free standing glass protective barriers**

Building Occupancy Class	Thickness in mm for glass type				
	Thermally Toughened Safety Glass	Toughened/Laminated Safety Glass using PVB interlayer		Toughened/Laminated Safety Glass using Ionoplast interlayer	
		With Handrail	With Handrail	Without Handrail	With Handrail
1	12	15.5	17.5	13.5	17.5
2	15	19.5	21.5	15.5	19.5
3	19	23.5	31.5	19.5	25.5
4	25	28.5	39.5	25.5	31.5

NOTE 1: The thicknesses stated in Table A5 are based upon glass width of 1200mm, exposed glass height 1100mm, and suitable base clamp.

NOTE 2: For other glass sizes, consult the manufacturer: